

MGS-RT



Thermostat controller with timer

Manual for the
specialised craftsman

Installation

Operation

Functions and options

Troubleshooting



11208917

11208917

Thank you for buying this MEGASUN product.
Please read this manual carefully to get the best performance from this unit.
Please keep this manual carefully.

Safety advice

Please pay attention to the following safety advice in order to avoid danger and damage to people and property.

Instructions

Attention must be paid to the valid local standards, regulations and directives!

Information about the product

Proper usage

The thermostat controller is designed for use in standard solar thermal systems, thermosiphon systems and heating systems with electric afterheating (electric immersion heater) in compliance with the technical data specified in this manual.

Improper use excludes all liability claims.

CE Declaration of conformity

The product complies with the relevant directives and is therefore labelled with the CE mark. The Declaration of Conformity is available upon request, please contact RESOL.



Note:

Strong electromagnetic fields can impair the function of the controller.

⚡ Make sure the controller as well as the system are not exposed to strong electromagnetic fields.

Subject to technical change. Errors excepted.

Target group

These instructions are exclusively addressed to authorised skilled personnel. Only qualified electricians should carry out electrical works. Initial installation must be effected by the system owner or qualified personnel named by the system owner.

Description of symbols

WARNING!



Warnings are indicated with a warning triangle!

⚡ They contain information on how to avoid the danger described.

Signal words describe the danger that may occur, when it is not avoided.

- WARNING means that injury, possibly life-threatening injury, can occur.
- ATTENTION means that damage to the appliance can occur.



Note:

Notes are indicated with an information symbol.

⚡ Arrows indicate instruction steps that should be carried out.

Disposal

- Dispose of the packaging in an environmentally sound manner.
- Dispose of old appliances in an environmentally sound manner. Upon request we will take back your old appliances bought from us and guarantee an environmentally sound disposal of the devices.

Thermostat controller with timer

The MGS-RT Thermostat controller is equipped with 2 high-current relays to which an electric immersion heater of up to 3.6 kW (230V~) can be connected.

Thus, the MGS-RT manages the time and temperature control of the electric backup heating for a DHW store. The rapid heat-up function makes for extra comfort. A wireline remote control with an integrated LED (MEGASUN RCTT) enables a comfortable operation of the rapid heat-up function.

Contents

1	Overview	4	5	Display and adjustment channels	8
2	Installation	5	5.1	Controller time	8
2.1	Mounting.....	5	5.2	Thermostat function.....	9
2.2	Electrical connection.....	6	5.3	Timer	10
3	Operation and function	7	5.4	Rapid heat-up.....	10
3.1	Buttons	7	5.5	Manual mode.....	11
3.2	Operation.....	7	6	RCTT Remote control (accessory)	11
4	System-Monitoring-Display	7			
4.1	Menu structure.....	8			

1 Overview

- Direct connection of an electric immersion heater up to 3.6 kW (230V~)
- Time and temperature control of the electric backup heating
- Rapid heat-up function with optional remote control activation
- Intuitive operating concept
- **Energy-efficient switch-mode power supply**
- Thermosiphon systems

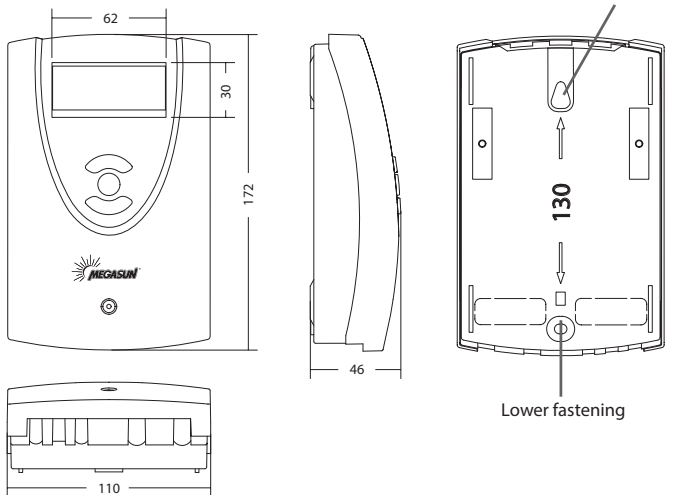

Technical data

Inputs: 1 Pt1000 temperature sensor, 1 input for RCTT Remote control

Outputs: 2 high-current relays for electric immersion heater

Switching capacity: 16 (3) A 240V~ (high-current relay)

Power supply: 100 ... 240V~ (50 ... 60 Hz)

Supply connection: type Y attachment

Standby: 0.44 W

Mode of operation: type 1.C action

Rated impulse voltage: 2.5 kV

Functions:

time-controlled thermostat function, DHW heating with rapid heat-up function

Housing: plastic, PC-ABS and PMMA

Mounting: wall mounting, also suitable for mounting into patch panels

Display: LC display, multi-functional combined display with pictograms, two 2-digit text fields and two 4-digit 7-segment displays

Operation: 3 buttons at the front of the housing

Protection type: IP 20 / DIN EN 60529

Protection class: II

Ambient temperature: 0 ... 40 °C

Degree of pollution: 2

Dimensions: 172 x 110 x 46 mm

Weight: 330 g

2 Installation

2.1 Mounting

WARNING!

Electric shock!

Upon opening the housing, live parts are exposed!

⚠ Always disconnect the device from power supply before opening the housing!



Note:

Strong electromagnetic fields can impair the function of the controller.

⚠ Make sure the controller as well as the system are not exposed to strong electromagnetic fields.

The unit must only be located in dry interior rooms.

The controller must additionally be supplied from a double pole switch with contact gap of at least 3 mm.

Please pay attention to separate routing of sensor cables and mains cables.

In order to mount the device to the wall, carry out the following steps:

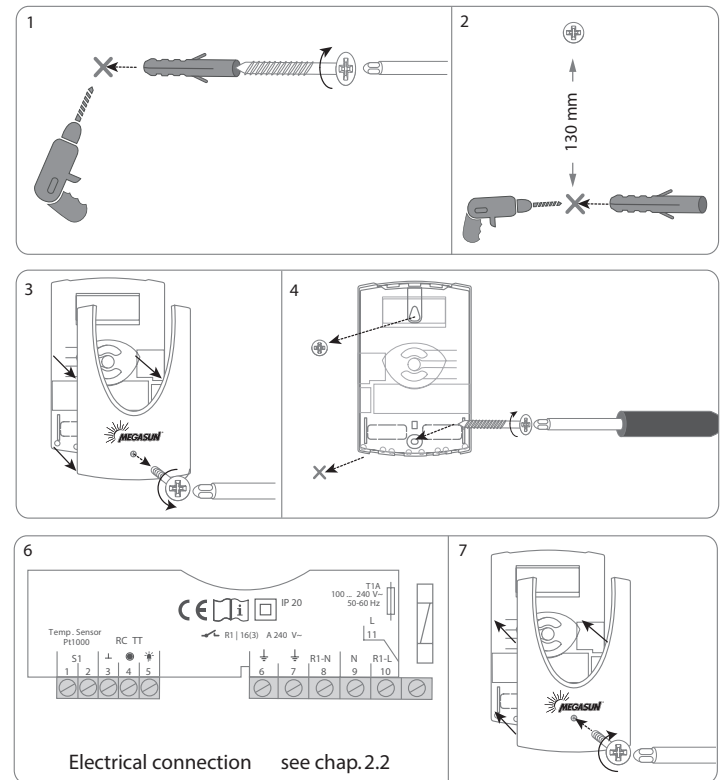

Made in Germany

2.2 Electrical connection

WARNING! Electric shock!
Upon opening the housing, live parts are exposed!
⚠ Always disconnect the device from power supply before opening the housing!

WARNING! ESD damage!
Electrostatic discharge can lead to damage to electronic components!
⚠ Take care to discharge properly before touching the inside of the device!

i Note:
The mains connection must be carried out with the common ground of the building to which the pipework of the system is connected.

i Note:
Connecting the device to the power supply must always be the last step of the installation!

i Note:
It must be possible to disconnect the device from the mains at any time.
⚠ Install the mains plug such that it is accessible at any time.
⚠ If this is not possible, install a switch that can be accessed.

Do not use the device if it is visibly damaged!

The power supply of the device must be 100... 240V~ (50 ... 60 Hz). Attach flexible cables to the housing with the enclosed strain relief and the corresponding screws.

The mains connection is at the following terminals:

9 = Neutral conductor N

11 = Conductor L

7 = Grounding terminal

Connect the temperature sensor (S1) to the following terminals with either polarity:

1/2 = Sensor 1 (e.g. store sensor)

Connect the RCTT Remote control (accessory) to the following terminals:

3 Switching input RCTT Remote control

4 GND RCTT Remote control

5 Signal LED output RCTT Remote control

The controller is equipped with 2 high-current relays (16 A) for connecting an electric immersion heater (up to 3.6 kW at 230 V~ or up to 1.8 kW at 115 V~ respectively):

6 Grounding terminal

10 Conductor electric immersion heater

8 Neutral conductor electric immersion heater

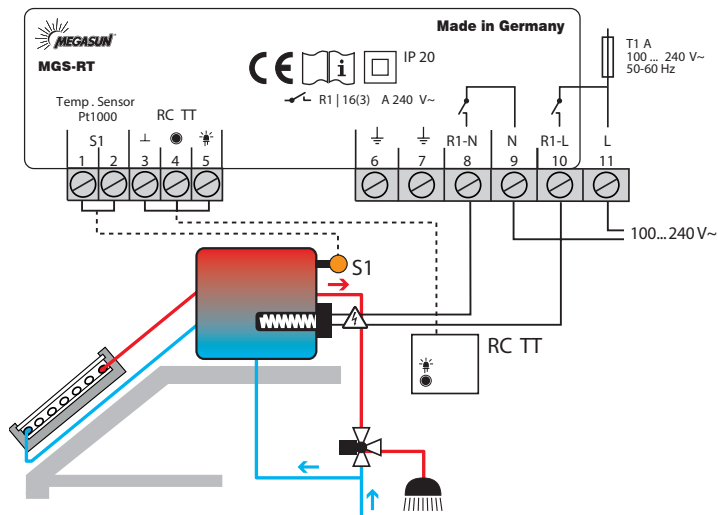

3 Operation and function

3.1 Buttons



- 1 Scrolling upwards/increasing adjustment values (+)
- 2 Scrolling downwards/reducing adjustment values (-)
- 3 Selection/adjustment mode/confirming

3.2 Operation

Accessing the adjustment mode

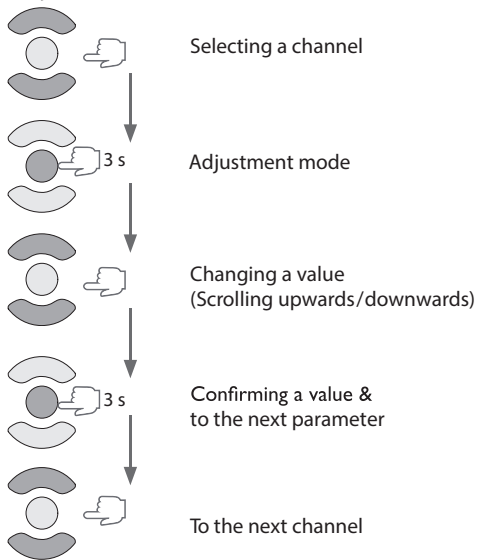

Note:
If the adjustment mode is active and if no button is pressed for 10s, the controller will automatically quit the adjustment mode.

4 System-Monitoring-Display



The System-Monitoring-Display consists of 2 blocks: channel display and tool bar.

Channel display



The channel display consists of 2 lines. In the 16-segment displays, parameter names are displayed. In the 7-segment displays, values are displayed.

Tool bar



The additional symbols in the tool bar indicate the current system state.

Permanently shown	Flashing	Status indications
①		Backup heating active, relay 1 switched on
① +		Rapid heat-up active, relay 1 switched on
	3x	Rapid heat-up not possible, because switch-off temperature exceeded
① +		Manual mode active, relay 1 switched on (ON)
		Manual mode active, relay 1 switched off (OFF)
	+	Sensor fault

4.1 Menu structure

The menu is structured as follows:

Channel	Parameter	Description	Display
Display channel 1	S1	Temperature sensor 1/store	S1 52.5
	R1	Status relay/electric immersion heater	R1 OFF
Display channel 2	t	Current time	t 11:55
Adjustment channel 1	t1	Switch-on temperature	T1 40°C
	t2	Switch-off temperature	T2 45°C
Adjustment channel 2	t1	Time frame 1 switch-on time	t1 07:00
	t2	Time frame 1 switch-off time	t2 08:00
Adjustment channel 3	t3	Time frame 2 switch-on time	t3 11:00
	t4	Time frame 2 switch-off time	t4 12:00
Adjustment channel 4	t5	Time frame 3 switch-on time	t5 18:00
	t6	Time frame 3 switch-off time	t6 20:00

5 Display and adjustment channels

5.1 Controller time

Adjustment channel	Description	Adjustment range	Factory setting
t	Time	00:00...23:59	

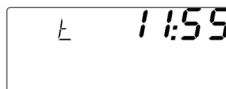

Indicates the current clock time.

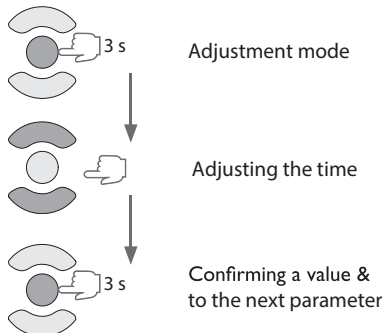

Note:
Adjust the current time so that the controller can function properly.

5.2 Thermostat function

Adjustment channel	Description	Adjustment range	Factory setting
T1	Switch-on temperature	0...90°C	40°C
T2	Switch-off temperature	5...95°C	45°C

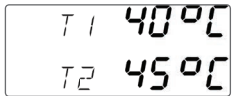

The thermostat function is used for controlling the backup heating.

If the temperature at sensor S1 falls below the adjusted switch-on temperature T1, backup heating will be switched on. If the temperature at sensor S1 reaches the adjusted switch-off temperature T2, backup heating will be switched off.

In order to prevent the backup heating from being switched on and off too often, the switch-on and switch-off temperatures T1 and T2 are blocked against each other.

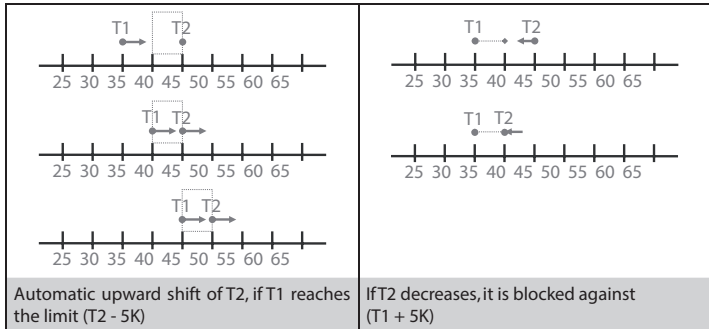

In order to avoid, but permit if necessary, long switch-on times of the backup heating, the switch-on and switch-off temperatures T1 and T2 are linked to each other.

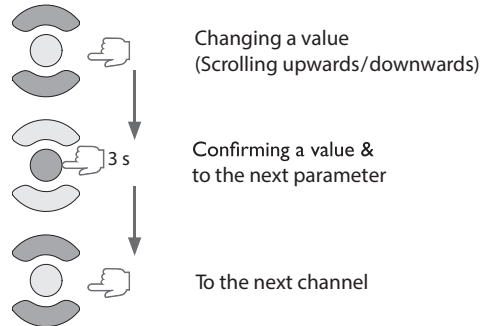
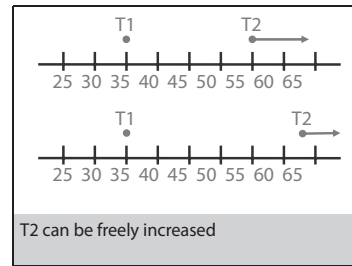
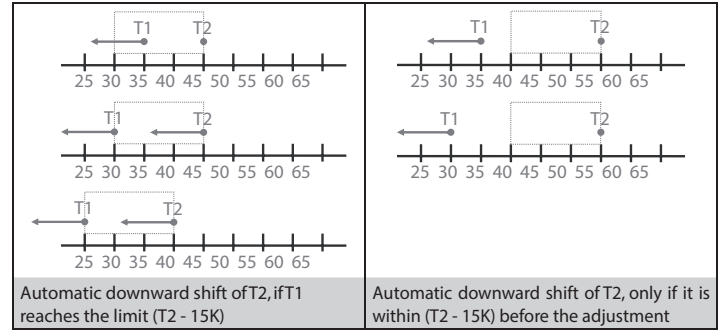

5.3 Timer

Adjustment channel	Description	Adjustment range	Factory setting
t1	Time frame 1 switch-on time	00:00...23:45	07:00
t2	Time frame 1 switch-off time	00:00...23:45	08:00
t3	Time frame 2 switch-on time	00:00...23:45	11:00
t4	Time frame 2 switch-off time	00:00...23:45	12:00
t5	Time frame 3 switch-on time	00:00...23:45	18:00
t6	Time frame 3 switch-off time	00:00...23:45	20:00

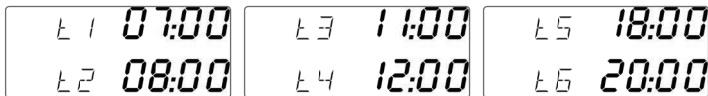

In order to block the thermostat function for a certain period, there are 3 time frames. They can be adjusted by means of the parameters switch-on and switch-off times (see table).

If the thermostat function is supposed to run from 06:00 a.m. to 09:00 a.m., adjust t3 to 06:00 a.m. and t4 to 09:00 a.m. Outside these time frames the backup heating is blocked and can be activated via the rapid heat-up function only.

If the switch-on and switch-off times of a time frame are set to an identical value, the time frame will be inactive. If all time frames are set to 00:00, the thermostat function is solely temperature dependent.

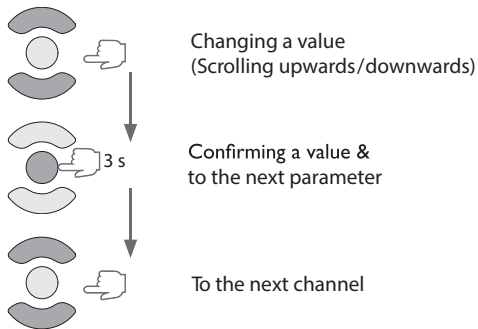

Note:

The time frames are not blocked against each other. If the values of 2 time frames overlap, they will be considered as 1 common time frame.

5.4 Rapid heat-up

Rapid heat-up enables immediate heating of the store even outside the adjusted time frames.

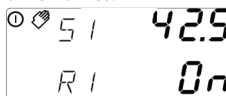

If rapid heat-up is activated, the controller will switch on the backup heating of the store. Rapid heat-up of the store will stop, if the switch-off temperature T2 is reached at sensor S1.

In order to activate the rapid heat-up, scroll to the **first display channel**, press and hold down button 1 for 3s. It is also possible to press the button of the RCTT Remote control (accessory) instead.



In order to deactivate the rapid heat-up, press and hold down the controller button 1 again for 3 s. It is also possible to press the button of the RCTT Remote control again instead.



Note:

If the temperature at sensor S1 exceeds the adjusted switch-off temperature T2 while rapid heat-up is being activated, rapid heat-up will be blocked. The controller will give feedback, see page 7 and page 11.



Note:

If the temperature at sensor S1 does not reach the switch-off temperature within 120 min after the rapid heat-up has started, the controller will switch off the backup heating of the store for safety reasons.

5.5 Manual mode

Adjustment channel	Description	Adjustment range	Factory setting
R1	Manual mode	On,Auto,Off	Auto



For control and service work, the operating mode of the relay can be manually adjusted. For this purpose, select the adjustment channel R1 in which the following adjustments can be made:

Adjustment mode of the manual mode

OFF : Relay off (flashing) +

Auto : Relay in automatic operation

ON : Relay on (flashing) + + ①

In order to access the adjustment channel R1 for adjusting the manual mode, scroll to the **first display channel**, press and hold down button 3 for 3 s.

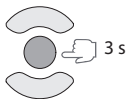

WARNING!

Electric shock!

Upon opening the housing, live parts are exposed!

⚠ Always disconnect the device from power supply before opening the housing!



Note:

Danger of high currents (16 A), if the manual mode is set to ON .



Note:

If the manual mode is set to ON , the controller will switch the manual mode back to Auto after 30 s for safety reasons.

6 RCTT Remote control (accessory)



The RCTT Remote control enables rapid heat-up activation via the button without having to access the controller menu. It is connected to the controller with a 3-wire cable (see page 6).

If the button of the RCTT is pressed, rapid heat-up will be activated on the controller. If rapid heat-up is already active, it will be deactivated.

If rapid heat-up is active on the controller, the LED of the RCTT will be permanently red.

If rapid heat-up is not possible, because the temperature at sensor S1 has exceeded the switch-off temperature T2, the LED of the RCTT will briefly flash 3 times.

In the case of a sensor fault, the LED of the RCTT will be flashing continuously.

The RCTT Remote control has to be connected to the controller according to the installation instructions mentioned in the RCTT Remote control manual.

Important note

The texts and drawings in this manual are correct to the best of our knowledge. As faults can never be excluded, please note:

Your own calculations and plans, under consideration of the current standards and directions should only be basis for your projects. We do not offer a guarantee for the completeness of the drawings and texts of this manual - they only represent some examples. They can only be used at your own risk. No liability is assumed for incorrect, incomplete or false information and / or the resulting damages.

Note

The design and the specifications can be changed without notice.
The illustrations may differ from the original product.

Imprint

This mounting- and operation manual including all parts is copyrighted. Another use outside the copyright requires the approval of MEGASUN-Elektronische Regelleistungen GmbH. This especially applies for copies, translations, micro films and the storage into electronic systems.

Distributed by:

MEGASUN MANUFACTURE CO. LTD.

Address: 387-388/5B- 5B Block – Tan Bien Ward
Bien Hoa City – Dong Nai province - Vietnam.

Tel. : 84 -613-882488 Fax : 84 -613-882434

Web: www.megasun.com.vn